



## 5G PHANTOM NO GROUND PLANE REQUIRED ANTENNAS

### Ground Plane Independent Low Profile Omni Antennas

The 5G Phantom no ground plane antenna series cover either 617-7125 or 698-7125 MHz in a ground plane independent format. Offering global cellular coverage, without the need for a fixed ground plane, even for regions where the lower 600 MHz band is required. They deliver high levels of average efficiency, over 95% up to 4200 MHz, and gain up to 8.0 dBi in an IP67-rated, compact form factor.

A direct-mount, threaded stud, with superior quality and integrated N-female connector provides tamper-resistant installation. The direct coaxial connection ensures performance remains consistent, even at the higher frequencies, avoiding the performance losses of other mounting methods.

### FEATURES AND BENEFITS

- Global cellular coverage – Available in 617-7125 MHz and 698-7125 MHz variants
- Minimum gain ripple around the horizon (Azimuth Plane) there is excellent consistency with minimal shifting gain
- Connectivity where you need it – Uniform azimuth patterns reduce the chance of signal drop outs
- Rugged, robust construction – Tamper-resistant and highly durable with IP67-rated enclosure and UL 94 flammability rating

#### ELECTRICAL SPECIFICATION

Part Number	FTRA6171M6PBN-001/ FTRA6171M6PWN-001						
Operating Frequency (MHz)	617-960	1427-1695	1695-2700	3300-4200	4400-6000	6000-6500	6500-7125
VSWR - Max	2.5:1	2.0:1	2.0:1	2.5:1	3.5:1	3.5:1	3.5:1
Peak Gain - Average (dBi)	0.2	1.6	3.3	6.1	7.5	7.9	8.6
Efficiency (%) Avg.	59	94	86	95	84	78	87
Part Number	FTRA6971M6PBN-001/ FTRA6971M6PWN-001						
Operating Frequency (MHz)	698-960	1427-1695	1695-2700	3300-4200	4400-6000	6000-6500	6500-7125
VSWR - Max	2.5:1	2.0:1	2.0:1	2.5:1	3.5:1	3.5:1	3.5:1
Peak Gain - Average (dBi)	0.4	1.1	2.7	5.7	6.6	7.4	8.1
Efficiency (%) Avg.	61	87	93	96	80	80	88
Polarization	Vertical						
Azimuth Beamwidth (All Models)	360 °, Omnidirectional						
Nominal Impedance (Ohms)	50						

## MECHANICAL SPECIFICATION

Dimensions - height x circumference - mm (in.)	113 x 47.3Ø (4.45 x 1.86) - 617-7125 MHz Models 96.5 x 47.3 Ø (3.80 x 1.86) - 698-7125 MHz Models
Weight - g (oz.)	280.9 (9.91)
Connector	Type N (female)
Radome	PolyCarbonate

## ENVIRONMENTAL SPECIFICATION

Operating Temperature - °C (°F)	-55 to +85°C (-67 to +185°F)
Storage Temperature - °C (°F)	-55 to +85°C (-67 to +185°F)
Ingress Protection (IP Rating)	IP67
Flammability Rating	UL94
Material Substance Compliance	RoHS Compliant

PART NUMBER	CONNECTOR	COLOR	FREQUENCY
FTRA6171M6PBN-001	Type N (female)	Black	617-7125 MHz
FTRA6171M6PWN-001	Type N (female)	White	617-7125 MHz
FTRA6971M6PBN-001	Type N (female)	Black	698-7125 MHz
FTRA6971M6PWN-001	Type N (female)	White	698-7125 MHz

## MECHANICAL DRAWINGS

FTRA6171M6PBN-001 & FTRA6171M6PWN-001

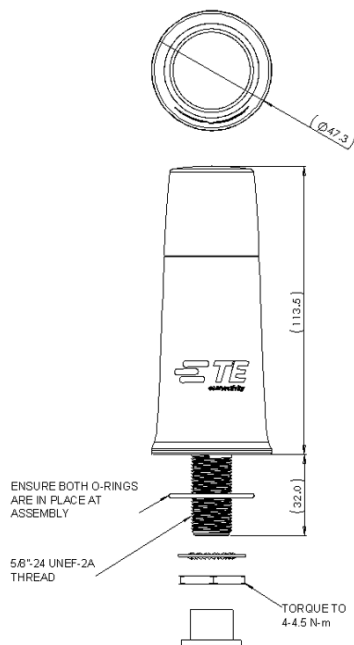

FTRA6971M6PBN-001 & FTRA6971M6PWN-001

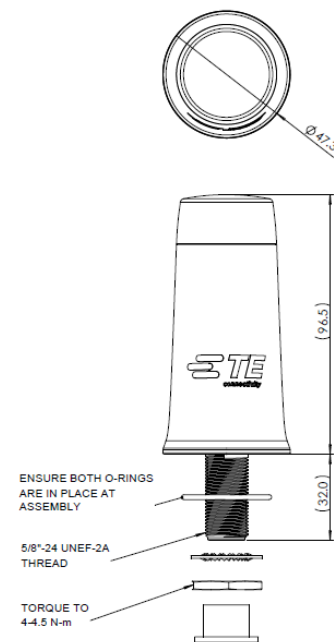

## RADIATION PATTERNS

The radiation patterns below are representative of both the 617-7125 and 698-7125 5G Phantom ground plane independent models. If required a full data set can be made available via our experience engineering teams.

### Radiation Patterns at 617 MHz (FTRA6171M6 Models Only)

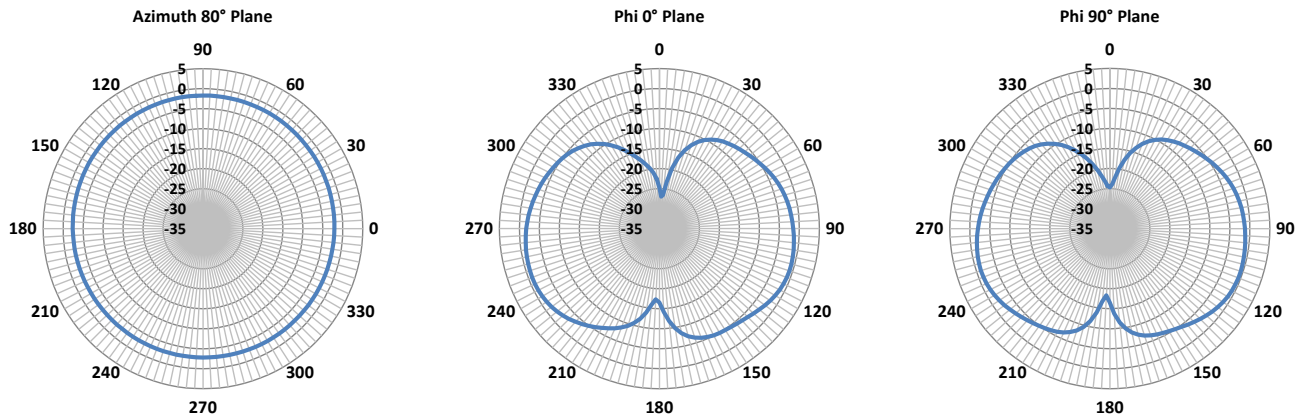

### Radiation Patterns at 698 MHz (All Models)

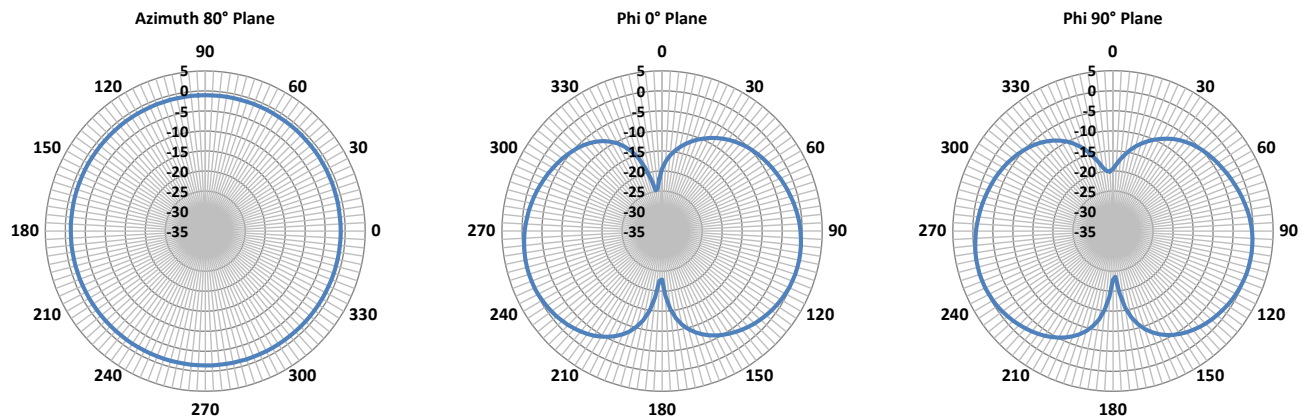

### Radiation Pattern at 746 MHz (All Models)

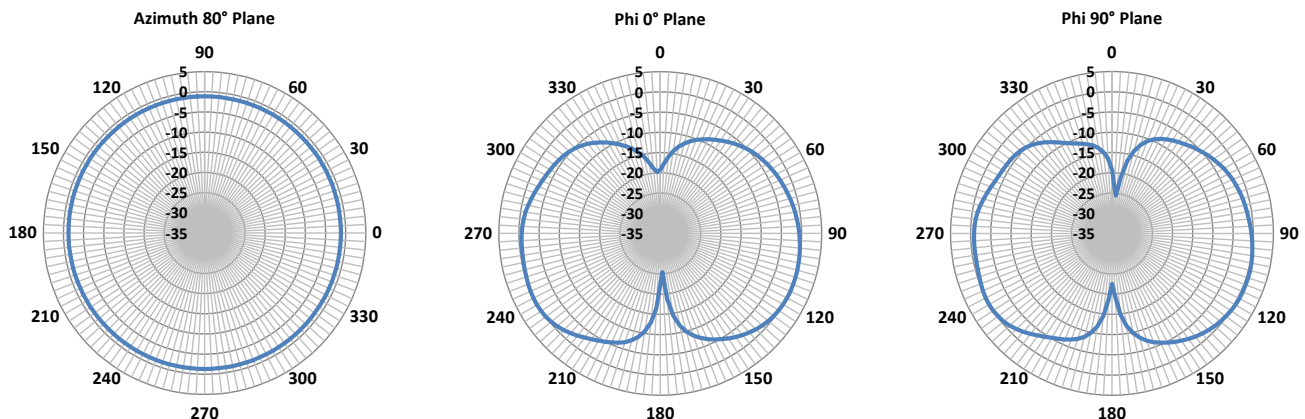

## Radiation Pattern at 824 MHz (All Models)

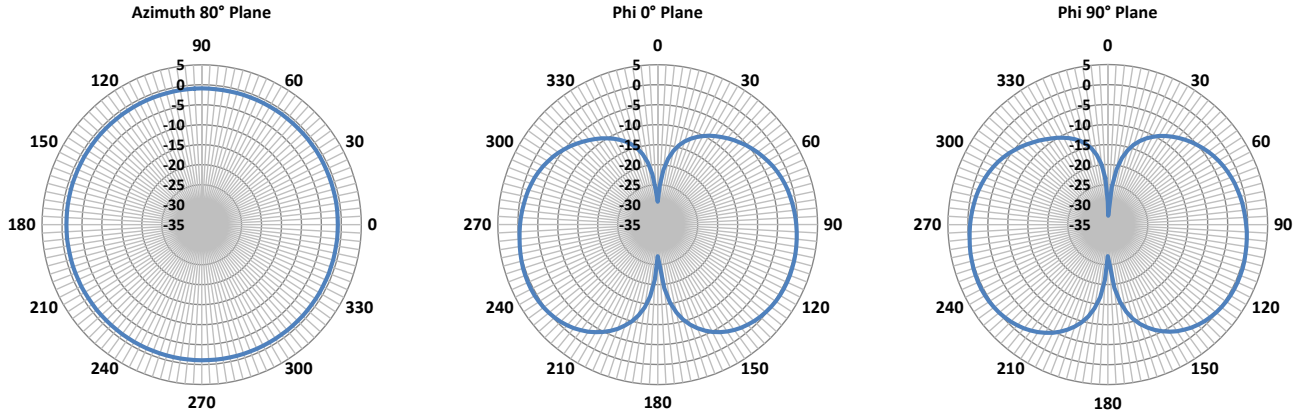

## Radiation Pattern at 960 MHz (All Models)

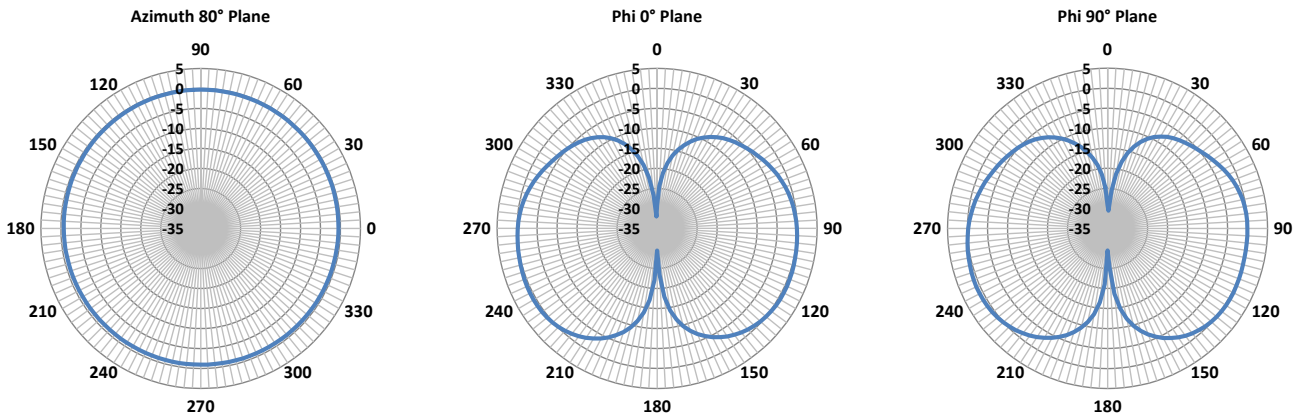

## Radiation Pattern at 1427 MHz (All Models)

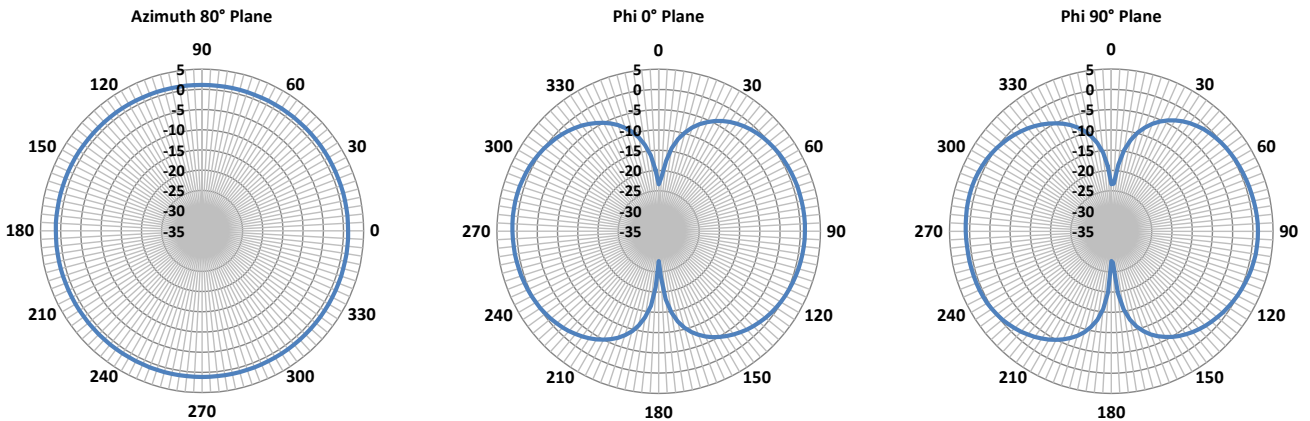

## Radiation Pattern at 1500 MHz (All Models)

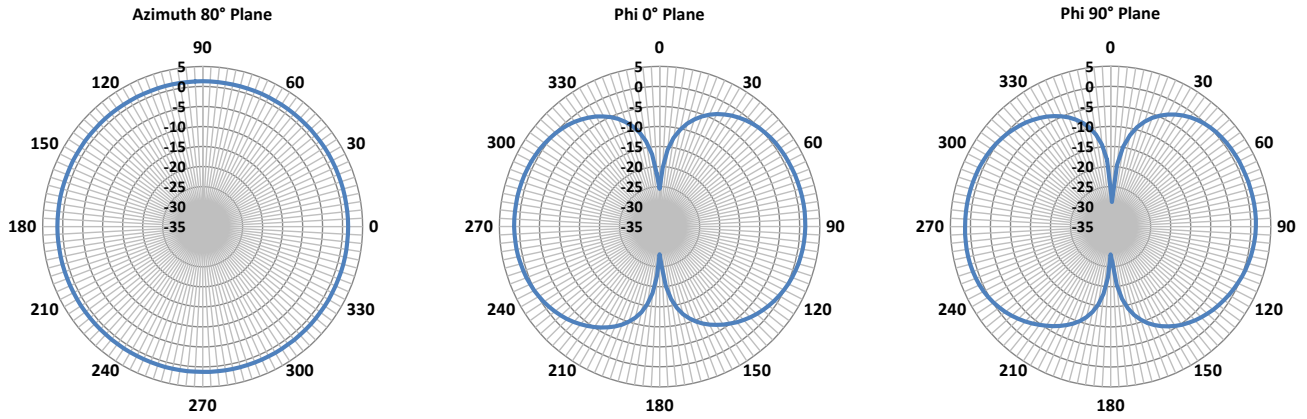

## Radiation Pattern at 1850 MHz (All Models)

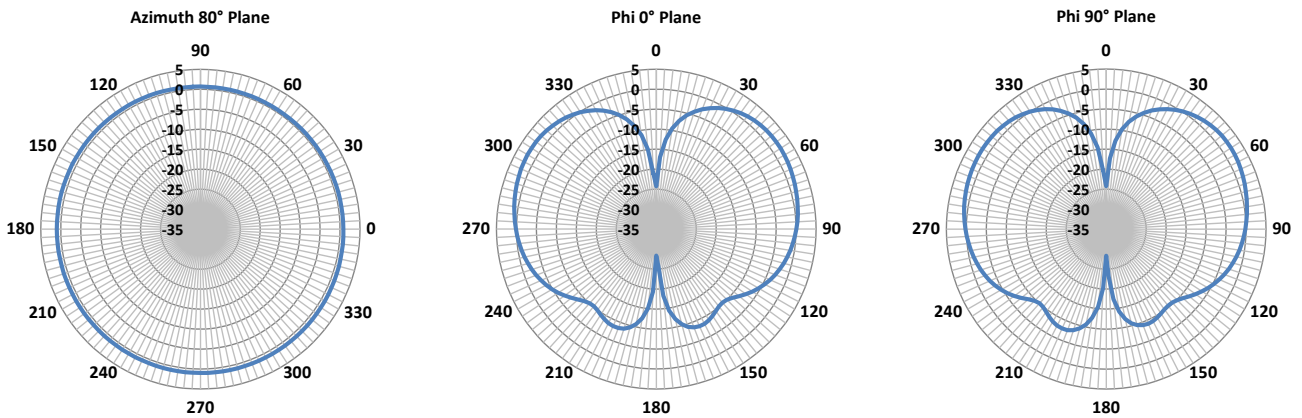

## Radiation Pattern at 2170 MHz (All Models)

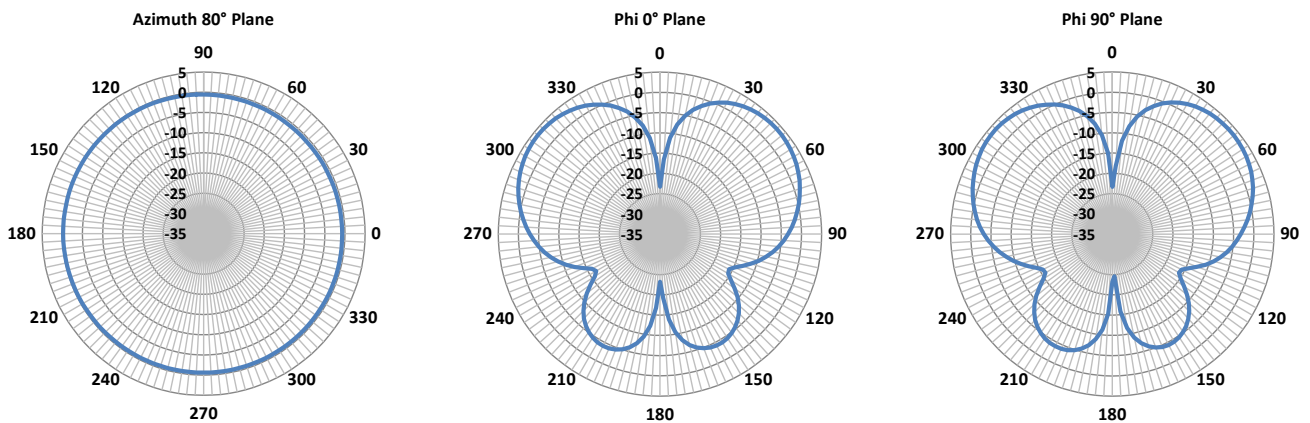

## Radiation Pattern at 2310 MHz (All Models)

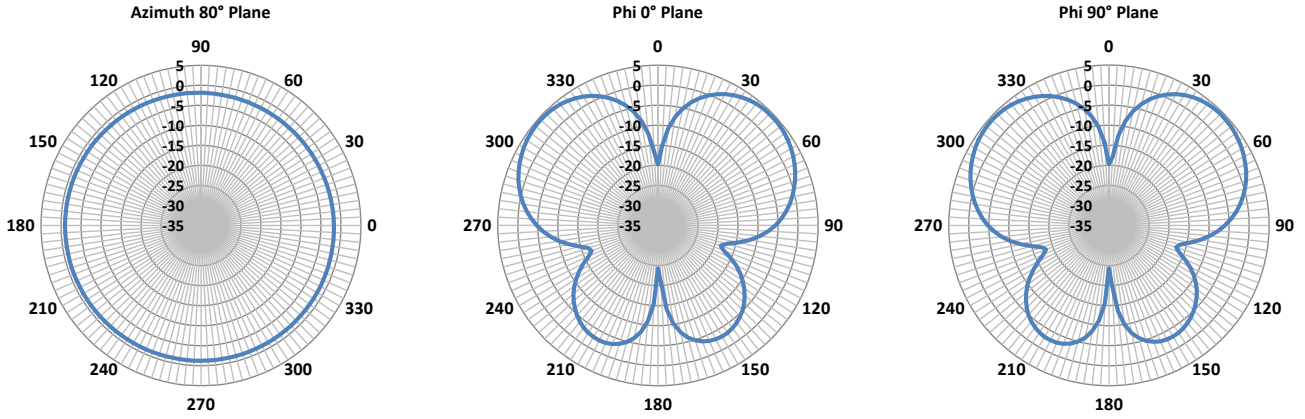

## Radiation Pattern at 2506.5 MHz (All Models)

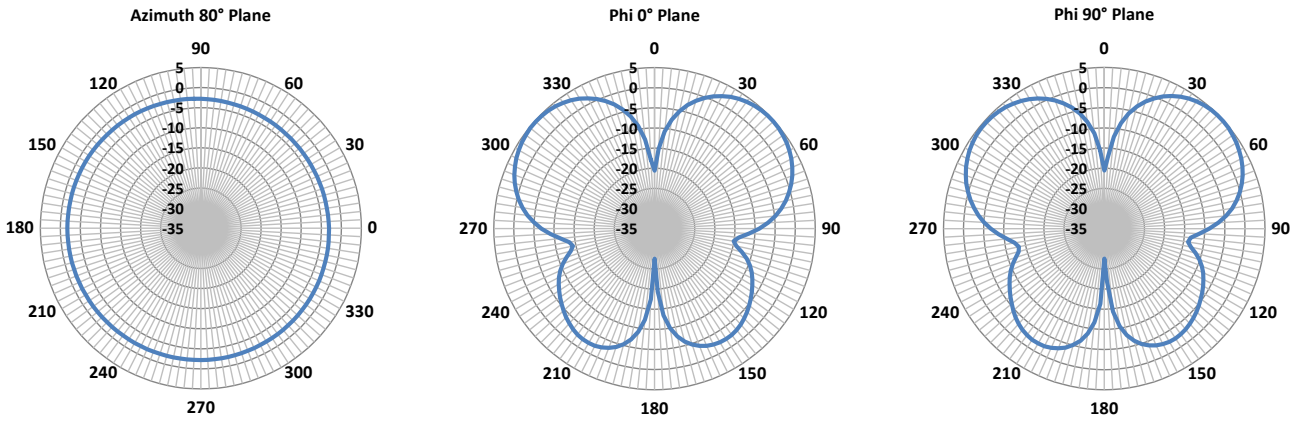

## Radiation Pattern at 2700 MHz (All Models)

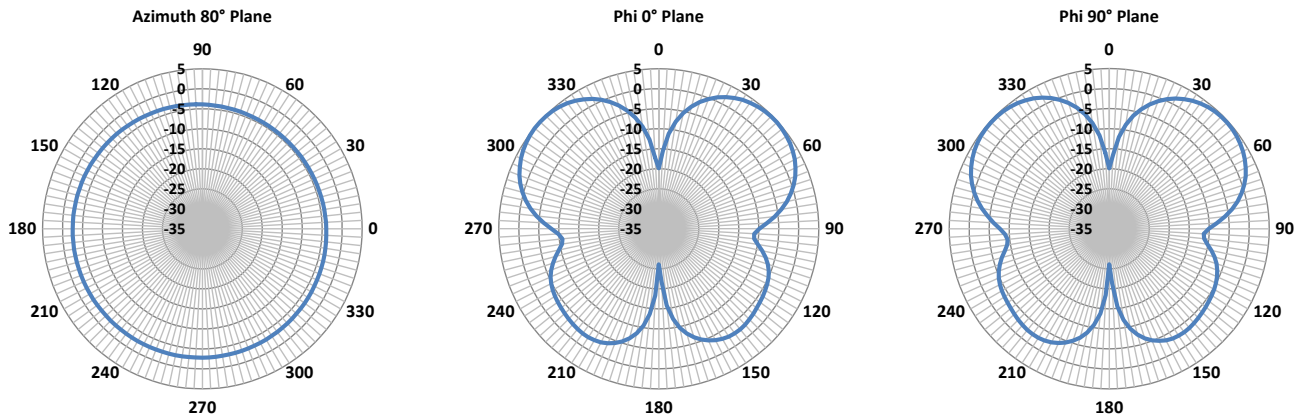

## Radiation Pattern at 3300 MHz (All Models)

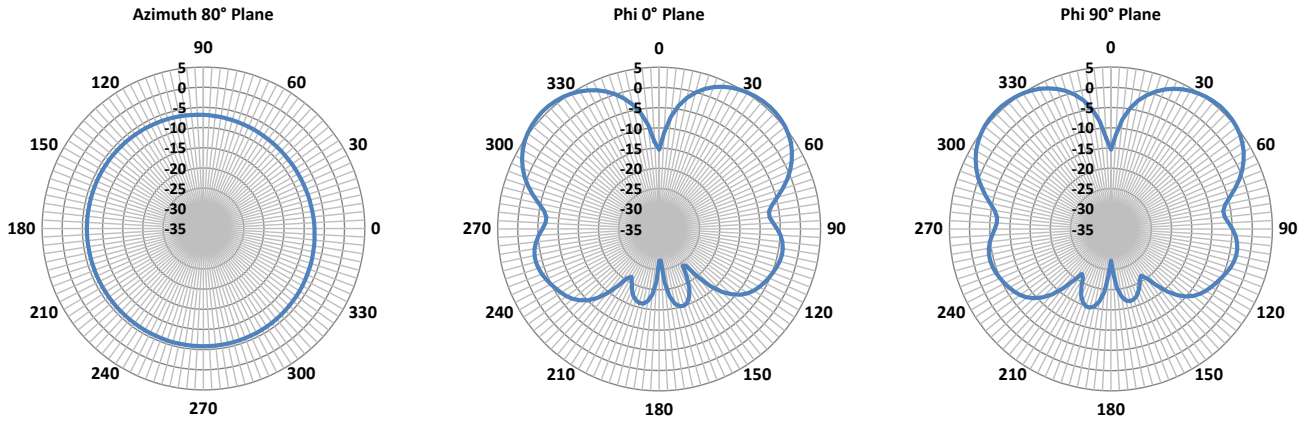

## Radiation Pattern at 3500 MHz (All Models)

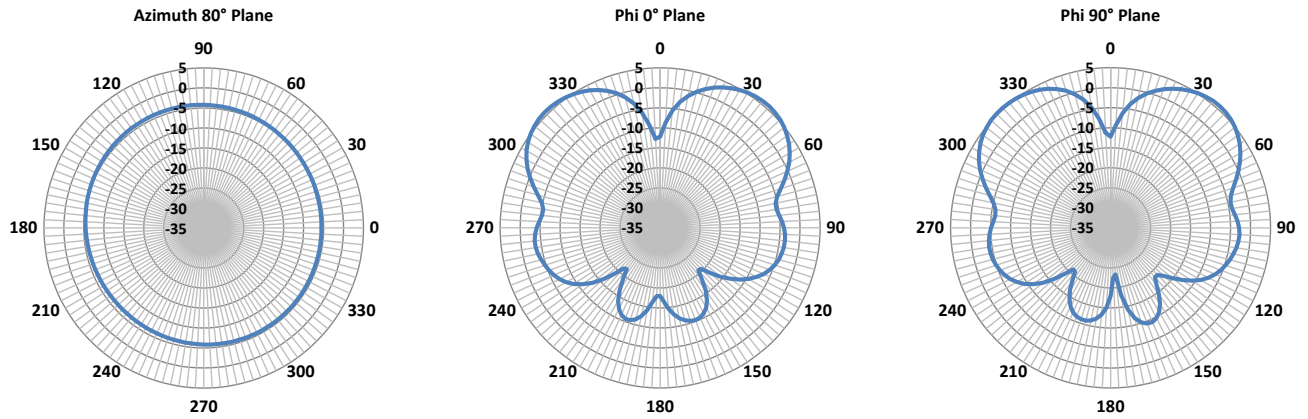

## Radiation Pattern at 3800 MHz (All Models)

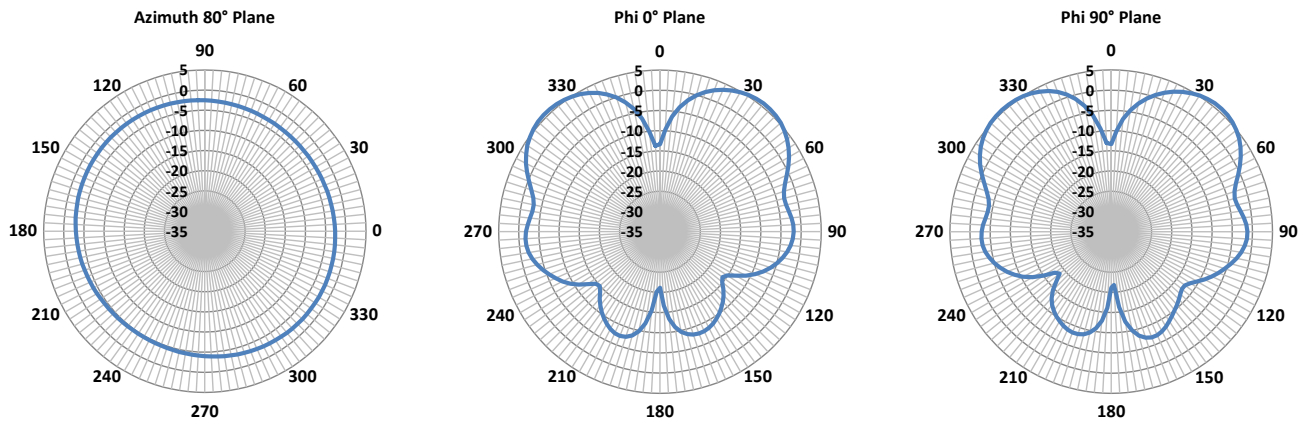

## Radiation Pattern at 4200 MHz (All Models)

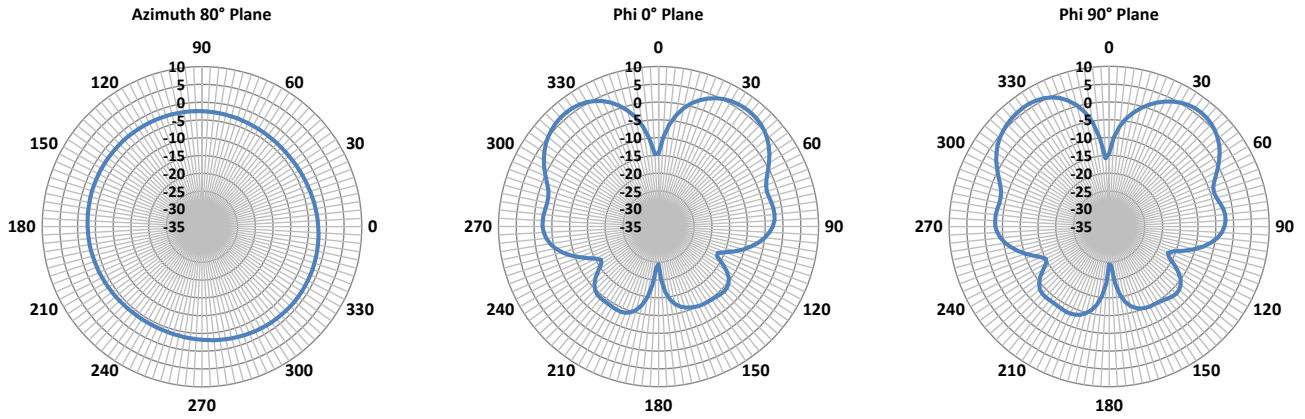

## Radiation Pattern at 4400 MHz (All Models)

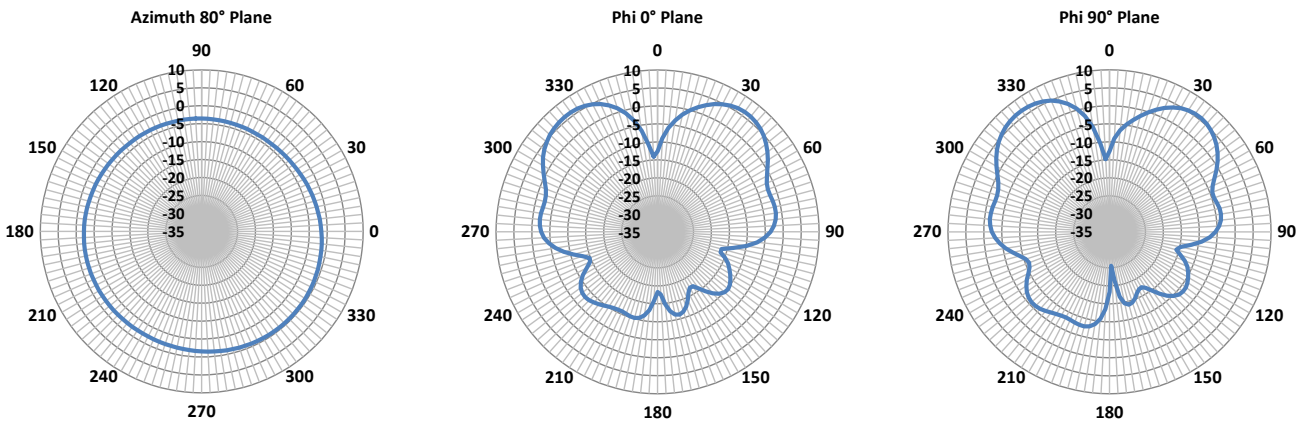

## Radiation Pattern at 5150 MHz (All Models)

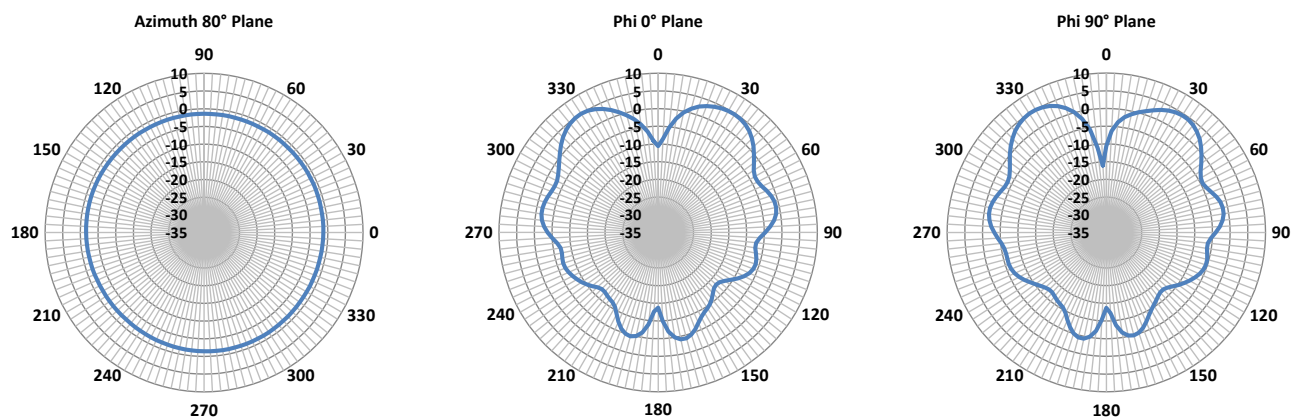

## Radiation Pattern at 5470 MHz (All Models)

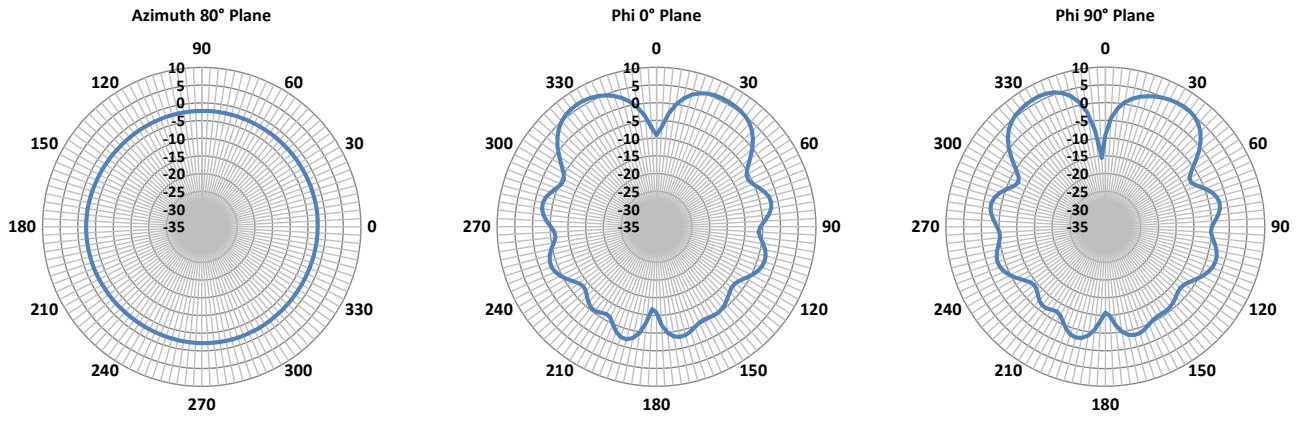

## Radiation Pattern at 5925 MHz (All Models)

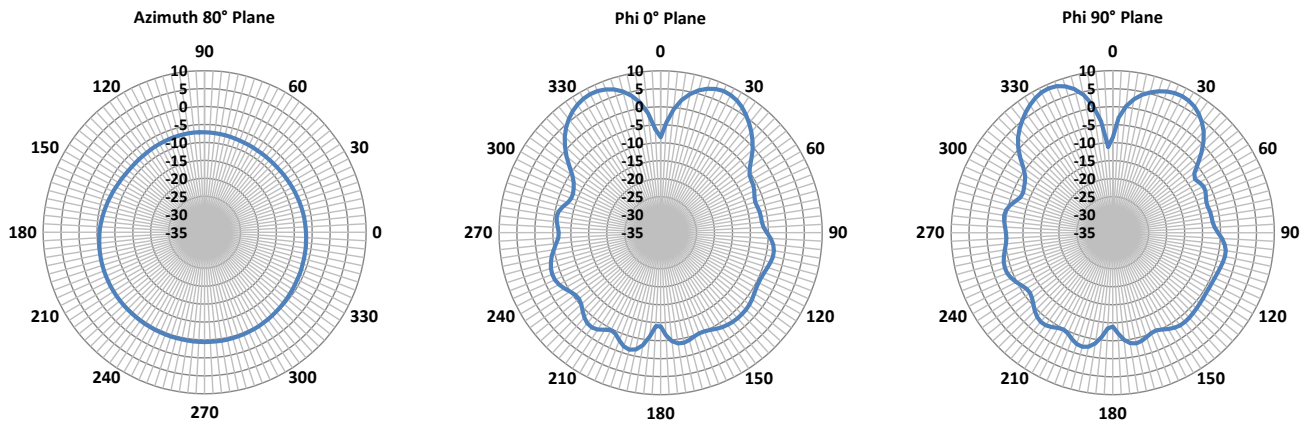

## Radiation Pattern at 6300 MHz (All Models)

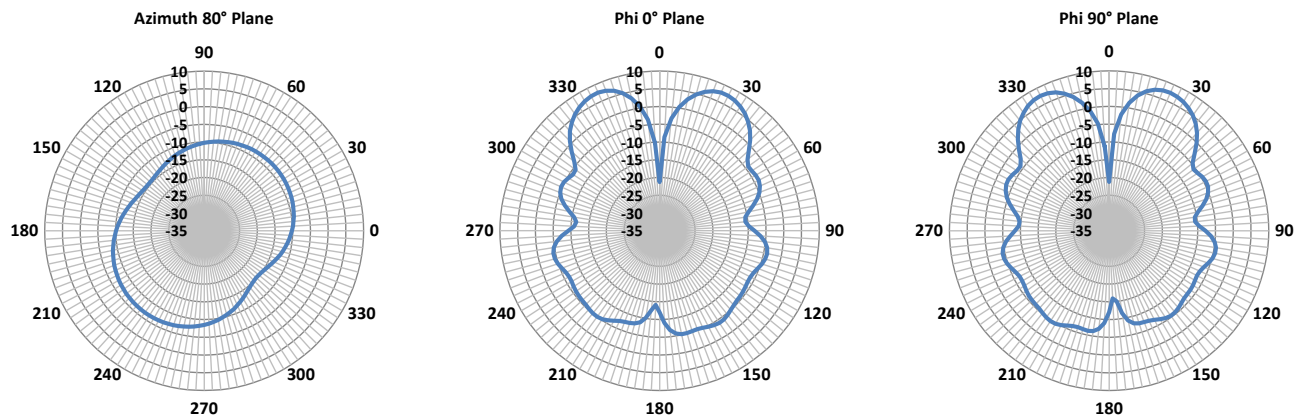

## Radiation Pattern at 6500 MHz (All Models)

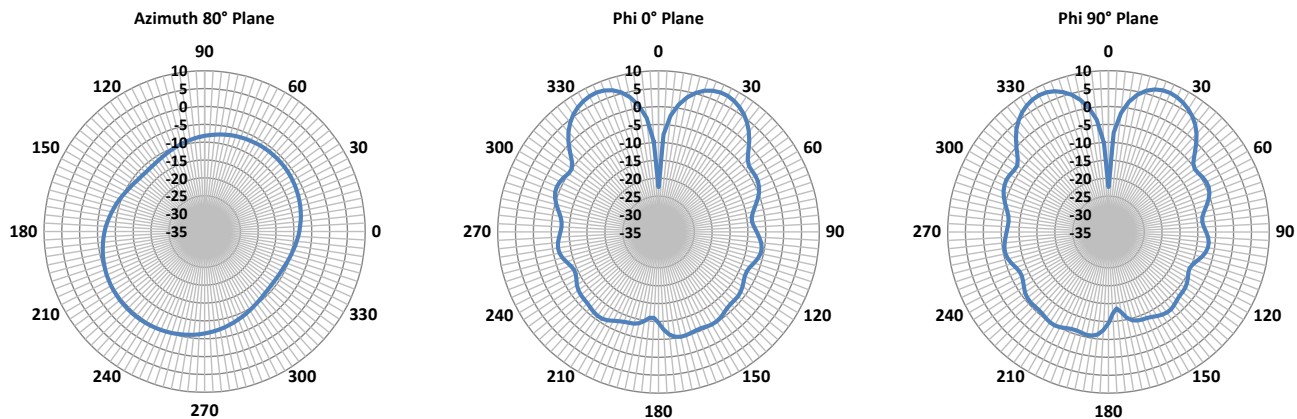

## Radiation Pattern at 6800 MHz (All Models)

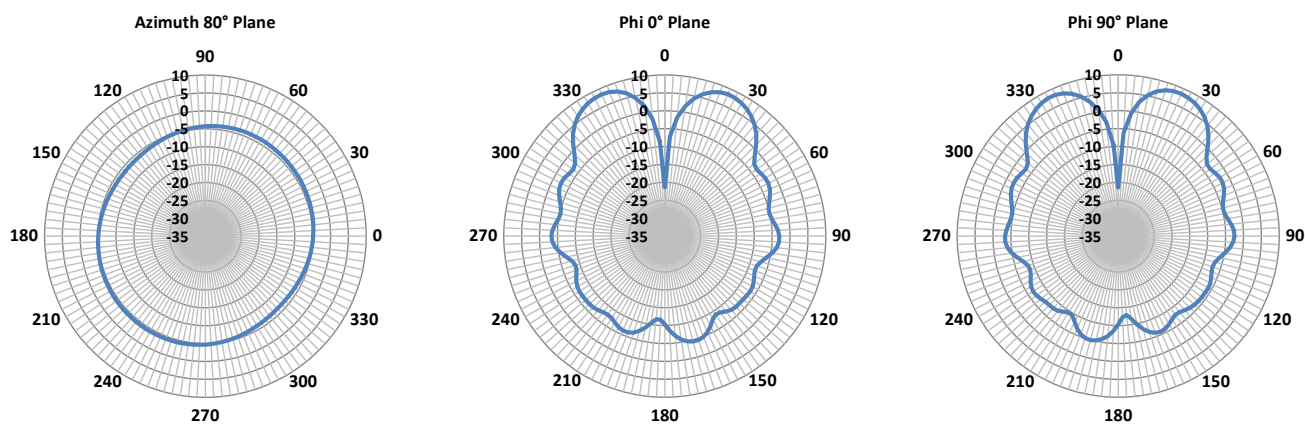

## Radiation Pattern at 7100 MHz (All Models)

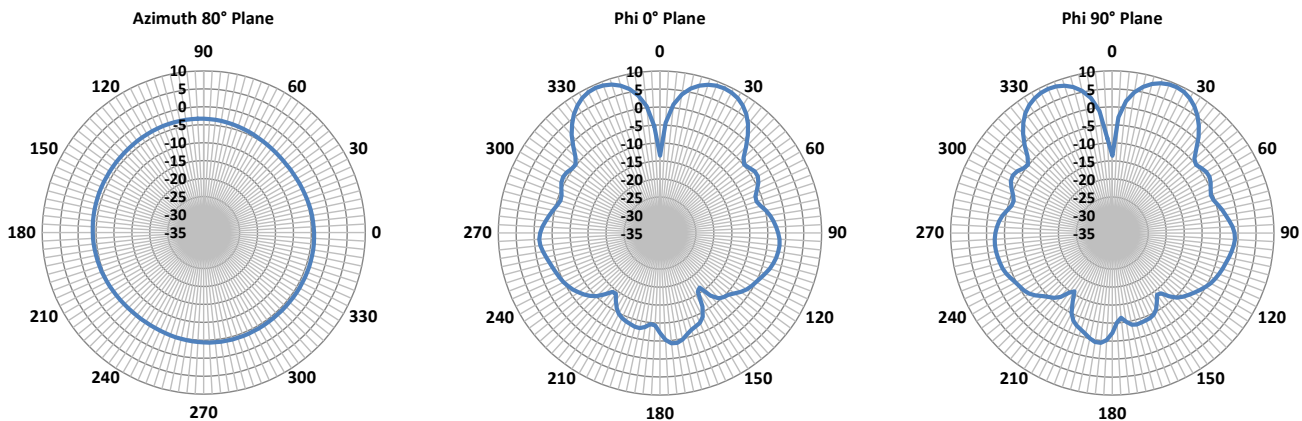

## PACKING INFORMATION

### PACKAGING - INDIVIDUAL CARTON

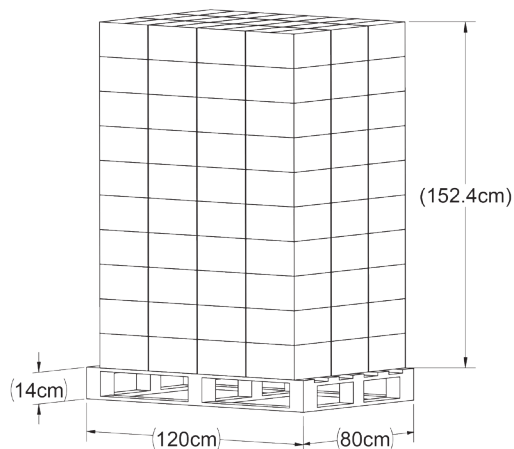

#### Ocean Shipping

Standard configuration information.

- Pallet 120cm X 80cm X 14cm, Weight 12kg
- Master carton @ 1 unit: Weight 8.23kg
- For ocean shipments 120 master carton with pallet: Weight 999.6kg (120cm x 80 cm x 152.4cm) 3000 total unit per pallet

### PACKAGING - BULK PACK

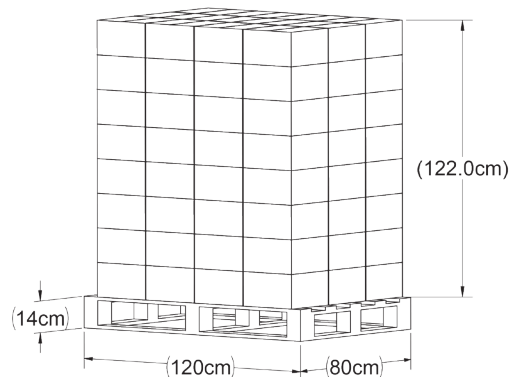

#### Air Shipping

Standard configuration information.

- Pallet 120cm X 80cm X 14cm, Weight 12kg
- Master carton @ 1 unit: Weight 8.23kg
- For Air shipments 96 master carton with pallet: Weight 802kg (120cm x 80 cm x 122.0cm) 2400 total unit per pallet

Antenna with bag pack

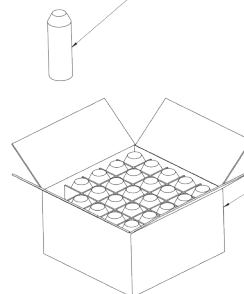

#### Master Carton

Internal Size (mm)  
:L260 X W260 X H150  
Total 25 unit Antennas pack

## TE TECHNICAL SUPPORT CENTER

USA:	+1 (800) 522-6752
Canada:	+1 (905) 475-6222
Mexico:	+52 (0) 55-1106-0800
Latin/S. America:	+54 (0) 11-4733-2200
Germany:	+49 (0) 6251-133-1999
UK:	+44 (0) 800-267666
France:	+33 (0) 1-3420-8686
Netherlands:	+31 (0) 73-6246-999
China:	+86 (0) 400-820-6015

## te.com

TE, TE Connectivity, TE connectivity (logo), and EVERY CONNECTION COUNTS are trademarks owned or licensed by the TE Connectivity plc family of companies. Other product names, logos, and company names mentioned herein may be trademarks of their respective owners.

While TE has made every reasonable effort to ensure the accuracy of the information in this document, TE does not guarantee that it is error-free, nor does TE make any other representation, warranty or guarantee that the information is accurate, complete, correct, reliable or current. TE reserves the right to make any adjustments to the information contained herein at any time without notice. TE EXPRESSLY DISCLAIMS ALL IMPLIED WARRANTIES REGARDING THE INFORMATION CONTAINED HEREIN, INCLUDING, BUT NOT LIMITED TO, ANY IMPLIED WARRANTIES OF MERCHANTABILITY OR FITNESS FOR A PARTICULAR PURPOSE. In no event will TE be liable for any direct, indirect, incidental, special or consequential damages arising from or related to recipient's use of the information. It is the sole responsibility of recipient of this information to verify the results of this information using their engineering and product environment. Recipient assumes any and all risks associated with the use of the information. Antenna performance may vary. TE is a component manufacturer, and customer and/or end-user is responsible for all end-use compliance and regulatory requirements.

©2025 TE Connectivity. All Rights Reserved.

05/25 Original